

RBP1 Belt Positioner

Installation, Operation and Maintenance Manual



RBP1 Belt Positioner

Purchase Date: _____

Purchased From: _____

Installation Date: _____

This information will be helpful for any future inquiries or questions about belt cleaner replacement parts, specifications or troubleshooting.

Table of Contents

Section 1 - Important Information	4
1.1 General Introduction	4
1.2 User Benefits	4
1.3 Proper Belt Trainer Selection.....	5
Section 2 - Safety Considerations and Precautions	6
2.1 Stationary Conveyors.....	6
2.2 Operating Conveyors.....	6
Section 3 - Pre-Installation Checks and Options	7
3.1 Checklist	7
3.2 Optional Installation Accessories.....	7
Section 4 - Installation Instructions	8
Section 5 - Pre-Operation Checklist and Testing	10
5.1 Pre-Op Checklist	10
5.2 Test Run the Conveyor	10
Section 6 - Maintenance	11
6.1 New Installation Inspection	11
6.2 Routine Visual Inspection	11
6.3 Routine Physical Inspection	11
6.4 Roller Replacement Instructions.....	12
6.5 Maintenance Log	13
6.6 Maintenance Checklist	14
Section 7 - Troubleshooting	15
Section 8 - Specs and CAD Drawings	16
8.1 Specs and Guidelines	16
8.2 CAD Drawing, RBP1 Small.....	17
8.3 CAD Drawing, RBP1 Medium	18
8.4 CAD Drawing, RBP1 Large.....	19
8.5 CAD Drawing, RBP1 Extra Large	20
Section 9 - Replacement Parts	21
9.1 Replacement Parts List	21
Section 10 - Other Flexco Conveyor Products	23

Section 1 - Important Information

1.1 General Introduction

We at Flexco are very pleased that you have selected a RBP1 Belt Positioner™ for your conveyor system.

This manual will help you to understand the installation, operation and maintenance of this product and assist you in making it work up to its maximum efficiency over its lifetime of service.

It is essential for safe and efficient operation that the information and guidelines presented be properly understood and implemented. This manual will provide safety precautions, installation instructions, maintenance procedures and troubleshooting tips. In addition, please follow all standard, approved safety guidelines when working on your conveyor.

If, however, you have any questions or problems that are not covered, please visit our web site or contact our Customer Service Department:

Customer Service: 49-7428-9406-0

Visit www.flexco.com for other Flexco locations and products.

Please read this manual thoroughly and pass it on to any others who will be directly responsible for installation, operation and maintenance of this impact bed. While we have tried to make the installation and service tasks as easy and simple as possible, **this product does however require correct installation and regular inspection and maintenance to maintain top working condition.**

1.2 User Benefits

Belt mistracking is a common problem that produces various problems, ranging from belt and structure damage to product spillage and safety issues. By utilizing the RBP1 Belt Positioner, it is possible to correct a belt that is mistracking and causing these problems. Multiple units may be required depending on the length of the mistracking belt.

Section 1 - Important Information

1.3 Proper Belt Trainer Selection

MODEL	APPLICATION RANGE
Belt Positioner™	Return side only, 140 n/mm (800 PIW) max tension on Small, Medium and Large; 210 n/mm (1200 PIW) max tension on Extra Large. Also works on reversing belts.
PTEZ™	Medium-duty belts up to 280 n/mm (1600 PIW) max tension. Also works on reversing belts.
PT Smart™	Medium-duty belts up to 280 n/mm (1600 PIW) max tension. Belt width + 75mm idler. Belt thickness 25mm maximum.
PT Smart™ Underground	Medium-duty belts up to 280 n/mm (1600 PIW) max tension. Belt width + 225mm idler. Belt thickness 25mm maximum. Fits underground structure.
PT Max™	Heavy-duty belts up to 525 n/mm (3000 PIW) max (generally over 19mm thick) Belt width 900 - 1500mm
HD PT Max™	Heavy-duty belts up to 1050 n/mm (6000 PIW) max tension. Belt width 1350 - 2100mm

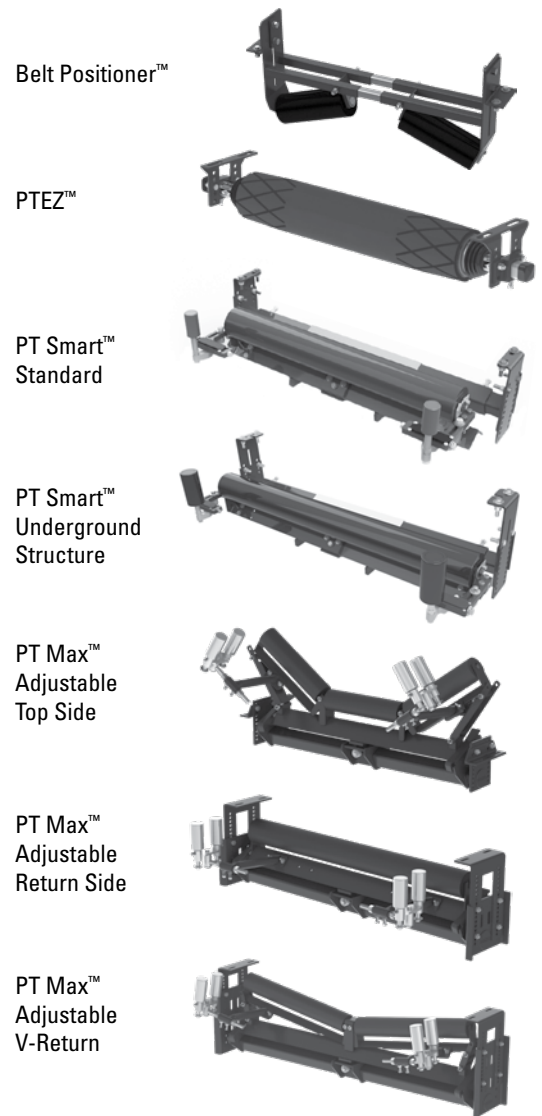

Conveyor Criteria	Belt Positioner™	PTEZ™	PT Smart™	PT Max™	PT Max™ Heavy Duty	PT Max™ Super Duty
Top side mistracking	No	No	No	Yes	Yes	Yes
Return side mistracking	Yes	Yes	Yes	Yes	Yes	Yes
Reversing belts	Yes	Yes	No	No	No	No
Belt mistracking to one side	Better	Better	Better	Better	Better	Better
Belt mistracking to both sides	Acceptable	Better	Best	Best	Best	Best
Inconsistent tracking problem	Good	Better	Best	Best	Best	Best
Belt is cupped (heavy)	Best ‡	Better‡	Better	Better	Better	Better
Belt has edge damage	Best	Best	Good	Good	Good	Good
Ease of installation	Best	Better	Good	Good	Good	Good
Belt has low running tension (26-53 n/mm)	Good	Good	Good	Good	N/A	N/A
Belt has medium running tension (53-280 n/mm)	Better	Better	Better	Best	Best	Best
Belt has high running tension (280+ PIW)	N/A	N/A	N/A	Better	Best	Best
Approx. "upstream" effect*Δ	15 M	6 M	6 M	15 M	15 M	15 M
Approx. "downstream" effect*Δ	15 M	30 - 36 M	36 - 45 M	45 - 61 M	45 - 61 M	45 - 61 M

‡ Installed on the clean side of the return belt

* Typical results; actual results may vary

Δ Disc idlers have the potential to reduce these numbers

Section 2 - Safety Considerations and Precautions

Before installing and operating the RBP1 Belt Positioner it is important to review and understand the following safety information.

There are setup, maintenance and operational activities involving both **stationary** and **operating** conveyors. Each case has a safety protocol.

2.1 Stationary Conveyors

The following activities are performed on stationary conveyors:

- Installation
- Skirt rubber adjustments
- Impact bar replacement
- Cleaning
- Repairs

DANGER

It is imperative that OSHA/MSHA Lockout/Tagout (LOTO) regulations, 29 CFR 1910.147, be followed before undertaking the preceding activities. Failure to use LOTO exposes workers to uncontrolled behavior of the impact bed caused by movement of the conveyor belt. Severe injury or death can result.

Before working:

- Lockout/Tagout the conveyor power source
- Disengage any takeups
- Clear the conveyor belt or clamp securely in place

WARNING

Use Personal Protective Equipment (PPE):

- Safety eyewear
- Hardhats
- Safety footwear

Close quarters and heavy components create a worksite that compromises a worker's eyes, feet and skull. PPE must be worn to control the foreseeable hazards associated with conveyor belt components. Serious injuries can be avoided.

2.2 Operating Conveyors

There are two routine tasks that must be performed while the conveyor is running:

- Inspection of the sealing performance
- Dynamic troubleshooting

DANGER

Every belt conveyor is an in-running nip hazard. Never touch or prod an operating impact bed. Conveyor hazards cause instantaneous amputation and entrapment.

WARNING

Conveyor chutes contain projectile hazards. Stay as far from the trainer as practical and use safety eyewear and headgear. Missiles can inflict serious injury.

WARNING

Never adjust anything on an operating impact bed. Unforeseeable materials falling into the chute can cause violent movements of the impact bed structure. Flailing hardware can cause serious injury or death.

Section 3 - Pre-installation Checks and Options

3.1 Checklist

- Check the model and size of the belt trainer. Is it the right one for your beltline?
- Check the RBP1 Belt Positioner to be sure all the parts are included in the shipment.
- Find the Information Packet in the shipment.
- Review the “Tools Needed” section on the front of the installation instructions.
- Prepare the conveyor site:
 - Identify the point(s) of mistracking, expecting 15M (50') of downstream and upstream influence.
 - Position the unit in the centre of the mistracking.
 - Optimal location: No closer than 15M (3') and no further than 1.8M (6') from a return roller.
 - Remove old tracking devices.

3.2 Optional Installation Accessories

Optional tools can make the installation of the RBP1 Belt Positioner easier and faster.

Flex-Lifter™ Conveyor Belt Lifter

Description	Ordering Number	Item Code
Medium Flex-Lifter 900 - 1500 mm (36" - 60")	FL-M	76469
Large Flex-Lifter 1200 - 1800 mm (48" - 72")	FL-L	76470
XL Flex-Lifter 1800 - 2400 mm (72" - 96")	FL-XL	76983

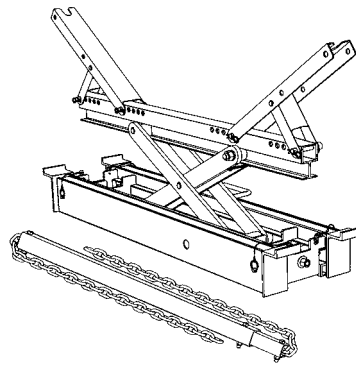

Flex-Lifter™ Conveyor Belt Lifter

The Flexco Flex-Lifter makes the job of lifting the conveyor belt easy and safe. Using two Flex-Lifters, the belt can be quickly lifted out of the way to install the PT Smart™. The Flex-Lifter has the highest safe lift rating available at 1810 kg. (4000 lbs.) for Medium and Large, 2750 kg. (6000 lbs.) for XL. And it's versatile. It can also be used to lift topside or return side belt for splicing, roller replacement or other maintenance jobs. Available in three sizes: Medium for belt widths 900 - 1500mm (36" - 60"), Large for belt widths 1200 - 1800mm (48" - 72"), and XL for belt widths 1800 - 2400mm (72" - 96").

Section 4 - Installation Instructions

4.1 RBP1 Belt Positioner

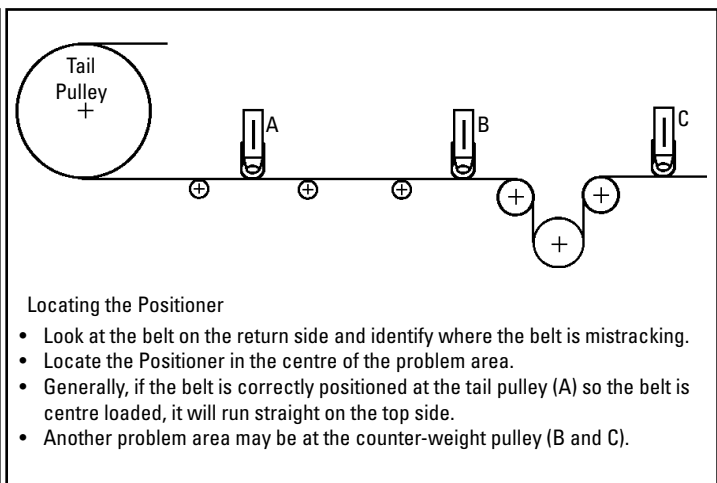
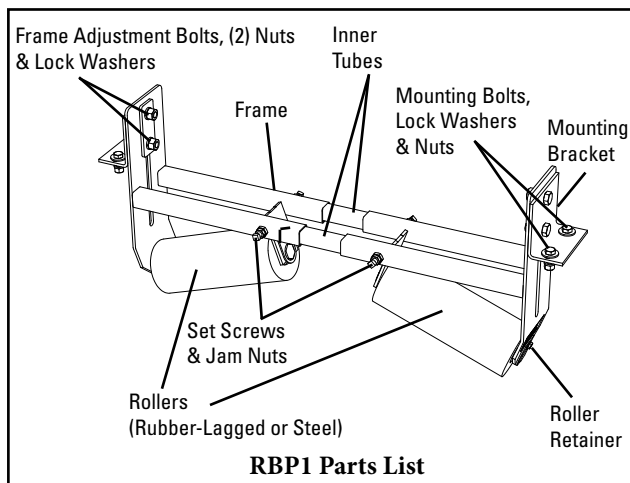

Physically lock out and tag the conveyor at the power source before you begin cleaner installation.

Tools Needed:

- Tape measure
- (2) 16 mm (5/8") wrench or crescent wrench
- (2) 13 mm (1/2") wrench or crescent wrench

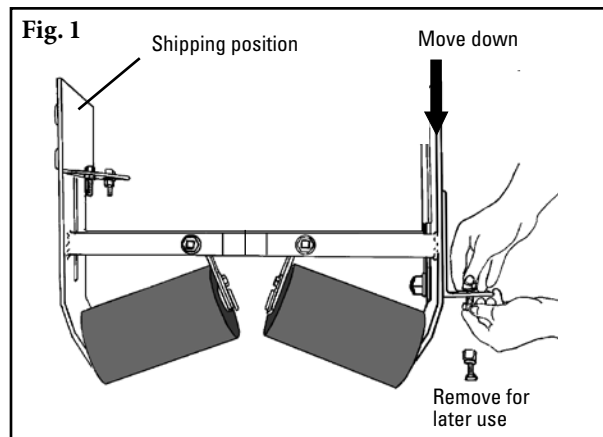

1. Reposition mounting brackets (Fig. 1). Remove the mounting brackets from the inner shipping position, move them down toward the rollers, and remount them on the outside of the frames. Remove the mounting bolts, lock washers and nuts from the brackets and set them aside for Step 4.

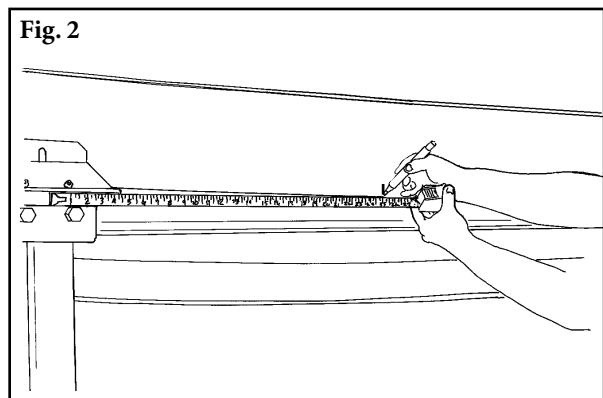

2. Determine Positioner location on the belt (in the selected location). Measure an equal distance from a common point on both sides of the structure and mark both sides at the measured points (Fig. 2). The unit must be square to the conveyor. **NOTE:** The Positioner should be centred between two standard return rollers. For general applications--standard belts up to 1800mm (72"): position the unit no closer than 15M (3') to a return roller and no farther than 1.8M (6').

Section 4 - Installation Instructions

4.1 RBP1 Belt Positioner

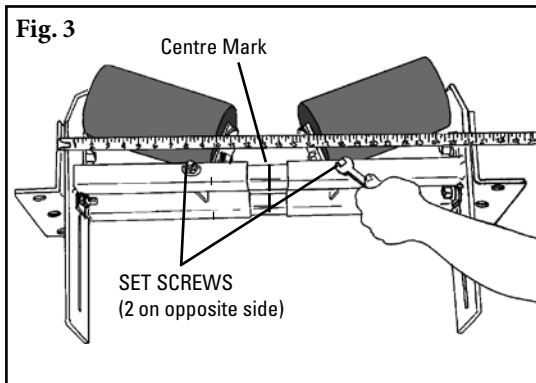

3. Adjust unit for conveyor width.

- Measure the structure's inside width from side to side.
- Loosen the four jam nuts and set screws on the frames and slide the unit apart to the same dimension as the inside structure width measurement minus 13mm (1/2") to ensure an easy fit. Retighten set screws and jam nuts (Fig. 3).

NOTE: The inner tubes between the two frames should be kept centred to ensure both sides have maximum support. Centre marks on the inner tubes make it easy to see that the tubes are centred.

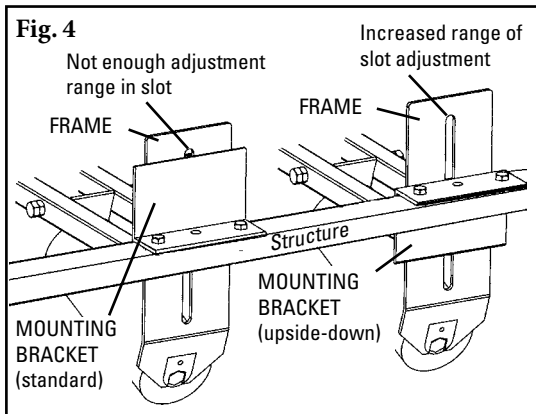

4. Mount unit on the conveyor.

Align the unit with the location marks on the structure.

NOTE: Check the slot adjustment range of the frame and the mounting bracket (Fig. 4). If there is not 100 to 150mm (4" to 6") of slot visible, turn the mounting brackets upside down for more slot adjustment. Clamp or hold the unit in place, drill mounting bolt holes on each side and secure with mounting bolts, lock washers and nuts, or weld in place.

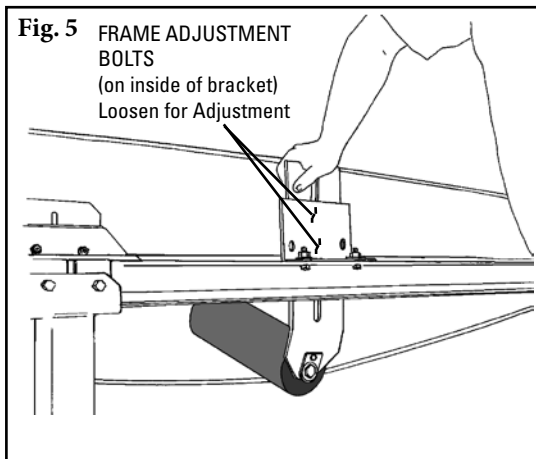

5. Adjust Positioner to the belt.

Loosen the two frame adjustment bolts on the side the belt is running off and apply pressures as follows (Fig. 5):

- Push down on unit until roller contacts 150 to 200mm (6" to 8") of the belt. The roller on the other side should be set to contact the belt 100mm (4") or less. Tighten all nuts.
- Allow the conveyor to run a minimum of five revolutions and evaluate the results.

IMPORTANT: If more correction is needed, increase the roller-to-belt contact pressure on the side running off; if necessary, decrease contact pressure on the opposite side.

MAINTENANCE

The rollers on the Positioner are sealed for life.

Section 5 - Pre-Operation Checklist and Testing

5.1 Pre-Op Checklist

- Recheck that all fasteners are tight
- Apply all supplied labels
- Be sure that all installation materials and tools have been removed from the belt and conveyor area

5.2 Test Run the Conveyor

- Run the conveyor for at least 15 minutes and confirm the belt is tracking properly.
- If belt is still mistracking too far to one side, increase the roller-to-belt contact pressure on the side running off; if necessary, decrease contact pressure on the opposite side.

Section 6 - Maintenance

Flexco belt trainers are designed to operate with minimum maintenance. However, to maintain superior performance some service is required. When the trainer is installed a regular maintenance program should be set up. This program will ensure that the trainer operates at optimal efficiency, and problems can be identified and fixed before any damage is done to the belt, the trainer, other conveyor components, or structure.

All safety procedures for inspection of equipment (stationary or operating) must be observed. The RBP1 Belt Positioner is in direct contact with the moving belt. Only visual observations can be made while the belt is running. Service tasks can be done only with the conveyor stopped and by observing the correct lockout/tagout procedures.

6.1 New Installation Inspection

After the RBP1 Belt Positioner has run for 15 minutes a visual inspection should be made to ensure the trainer is performing properly. Make adjustments as needed.

6.2 Routine Visual Inspection (every 2-4 weeks)

A visual inspection of the RBP1 Belt Positioner can determine:

- If the belt is tracking as required
- If the main frame is free of material and rolling properly
- If there is damage to the main frame or other components
- If the rollers are turning freely and without damage

If any of the above conditions exist, a determination should be made on when the conveyor can be stopped for trainer maintenance.

6.3 Routine Physical Inspection (every 6-8 weeks)

When the conveyor is not in operation and properly locked and tagged out, a physical inspection of the trainer to perform the following tasks:

- Clean material buildup off the trainer and components.
- Closely inspect main roller for free movement and wear. Replace if needed.
- Closely inspect complete unit for damage.
- Inspect all fasteners for tightness and wear. Tighten or replace if needed.
- When maintenance tasks are completed, test run the conveyor to ensure the trainer is performing properly.

Section 6 - Maintenance

6.4 Roller Replacement Instructions

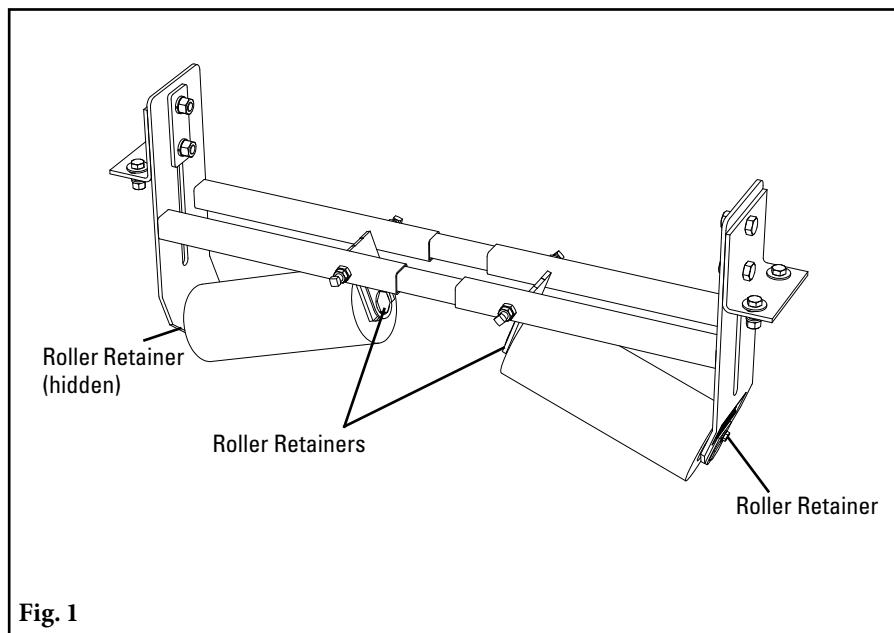

Physically lock out and tag the conveyor at the power source before you begin cleaner installation.

Tools Needed:

- Tape measure
- 8 mm (5/16") wrench or crescent wrench

CAUTION: Components may be heavy. Use safety-approved lifting procedures.

- 1. Remove tension from belt.** Use a Flex-Lifter or other appropriate lifting equipment to lift the belt approx. 75mm (3") off the trainer.
- 2. Remove roller** by unbolting (4) Roller Retainers (Fig. 1).
- 3. Install new roller** and re-bolt Roller Retainers (Fig. 1). Confirm roller turns smoothly.
- 4. Lower the belt.** Ensure belt completely contacts rollers. Lower brackets if there is not good contact. Tighten all bolts.
- 5. Refer to pre-op checklist (page 10) before running the conveyor.** If belt is still mistracking, refer to Section 5.2 on page 10.

Section 6 - Maintenance

6.5 Maintenance Log

Conveyor Name/No. _____

Date: _____ Work done by: _____ Service Quote #: _____

Activity: _____

Date: _____ Work done by: _____ Service Quote #: _____

Activity: _____

Date: _____ Work done by: _____ Service Quote #: _____

Activity: _____

Date: _____ Work done by: _____ Service Quote #: _____

Activity: _____

Date: _____ Work done by: _____ Service Quote #: _____

Activity: _____

Date: _____ Work done by: _____ Service Quote #: _____

Activity: _____

Date: _____ Work done by: _____ Service Quote #: _____

Activity: _____

Date: _____ Work done by: _____ Service Quote #: _____

Activity: _____



Section 6 - Maintenance

6.6 Belt Trainer Maintenance Checklist

RBP1 Belt Positioner: _____ **Serial Number:** _____

Beltline Information:

Beltline Number: _____ Belt Condition: _____

Belt Width: 450mm 600mm 750mm 900mm 1050mm 1200mm 1350mm 1500mm 1800mm 2100mm 2400mm
(18") (24") (30") (36") (42") (48") (54") (60") (72") (84") (96")

Belt Speed: _____ Belt Thickness: _____

Idler Roller Life (Right Side):

Date Roller Installed: _____ Date Roller Inspected: _____ Estimated Roller Life: _____

Roller Condition: _____

Idler Roller Life (Left Side):

Date Roller Installed: _____ Date Roller Inspected: _____ Estimated Roller Life: _____

Roller Condition: _____

RBP1 Frame Condition: Good Bent Rusted

Overall RBP1 Performance: (Rate the following 1 - 5, 1=very poor - 5= very good)

Appearance: Comments: _____

Location: Comments: _____

Maintenance: Comments: _____

Performance: Comments: _____

Other Comments: _____

Section 7 - Troubleshooting

Problem	Possible Cause	Possible Solutions
Little to no effect on trouble area of belt	Unit installed in wrong location	Relocate in the centre of problem area of belt
	Incorrect tension on unit	Lower height of unit to provide 13 - 25mm (1/2" - 1") pressure on belt
	Unit mis-adjusted	Go to step 5 of Installation Instructions
	Buildup on main roller	Clean unit
Belt not correcting enough	Unit mis-adjusted	Go to step 5 of Installation Instructions
Belt moving over too much	Unit mis-adjusted	Go to step 5 of Installation Instructions
Roller not turning	Buildup on main roller	Clean unit
	Roller bearing bad	Replace roller

Section 8 - Specs and CAD Drawings

8.1 Specs and Guidelines

Belt Width Specifications

Size	Belt Width (Min-Max)		Positioner Width (Min-Max)	
	mm	in.	mm	in.
Small	450-600	18-24	600-850	24-34
Medium	750-1200	30-48	850-1400	34-56
Large	1350-1800	54-72	1400-2075	56-83
Extra Large	1800-2400	72-96	1800-3000	72-120

Use next larger size for belt widths between ranges.

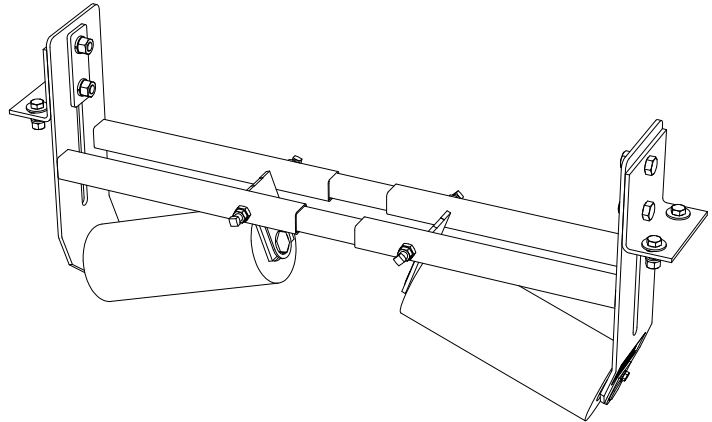

- Belt Splice Mechanically Fastened/Vulcanized
- Belt Speed..... 5m/s (1000 FPM)
- Belt Direction..... Reversing

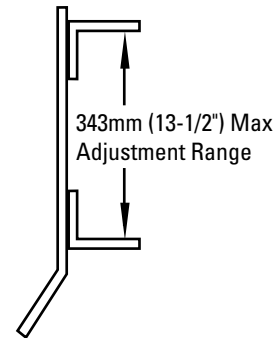

Roller Specifications

Specification	Steel & Rubber	Steel
Material	STEEL and 3/8" RUBBER	STEEL
Durometer	60	N/A
Rating	CEMA D (XL is CEMA E)	CEMA D (XL is CEMA E)
Bearings	6305 Sealed Ball Bearing	6305 Sealed Ball Bearing
Shaft Diameter	25mm (1")	25mm (1")
Wall Thickness	9 Gauge (.148) (XL - 6mm)	9 Gauge (.148) (XL - 6mm)
Specific Gravity	Over 1	Over 1
Working Temperature		
°C	-20° to 104°	-20° to 104°
°F	-4° to 220°	-4° to 220°
Grease & Chemical Resistance	Good	Good
Sticky Material Performance	Excellent	Good

Roller Dimensions

Size	Length		Diameter	
	mm	in.	mm	in.
Small	225	9	125	5
Medium	325	13	125	5
Large	475	19	125	5
Extra Large	525	21	150	6

- Optimal location: no closer than 15M (3') and no further than 1.8M (6') from a return roller.
- All rollers are "sealed for life". No regreasing maintenance is required.
- MSHA approved.

Section 8 - Specs and CAD Drawings

8.2 CAD Drawing - RBP1 Belt Positioner- Small

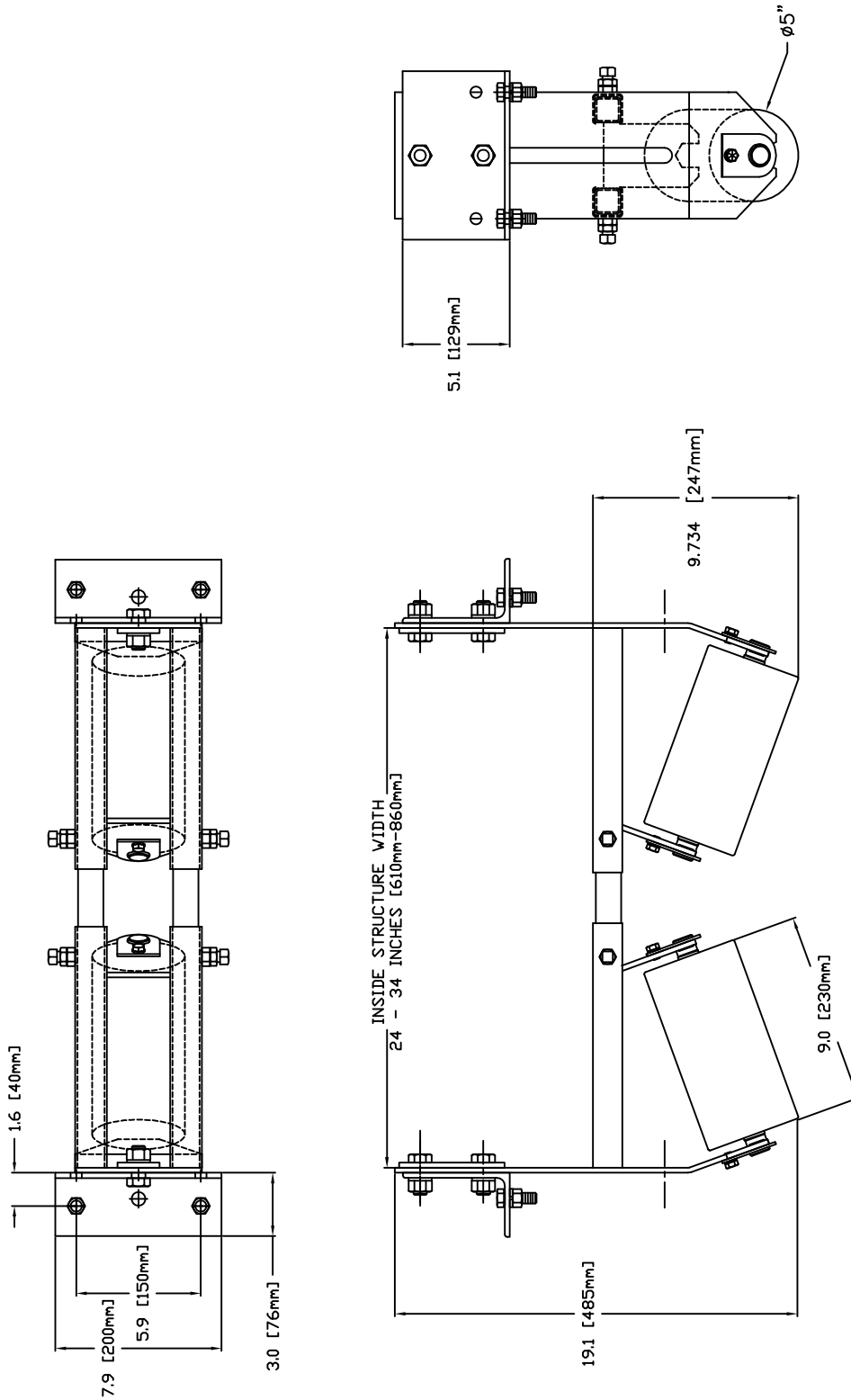

"PERSUADER" BELT POSITIONER
 SIZE: SMALL 73140 AND 74558
 BELT WIDTH: 18 - 24 INCHES
 INSIDE STRUCTURE WIDTH: 24 - 34 INCHES
 VERTICAL ADJUSTMENT RANGE: 8-1/8 INCHES
 VERTICAL ADJUSTMENT RANGE BY REVERSING
 MOUNTING BRACKET: 13-3/8 INCHES
 MINIMUM CLEARANCE BETWEEN BELTS - 10"

Section 8 - Specs and CAD Drawings

8.3 CAD Drawing - RBP1 Belt Positioner- Medium

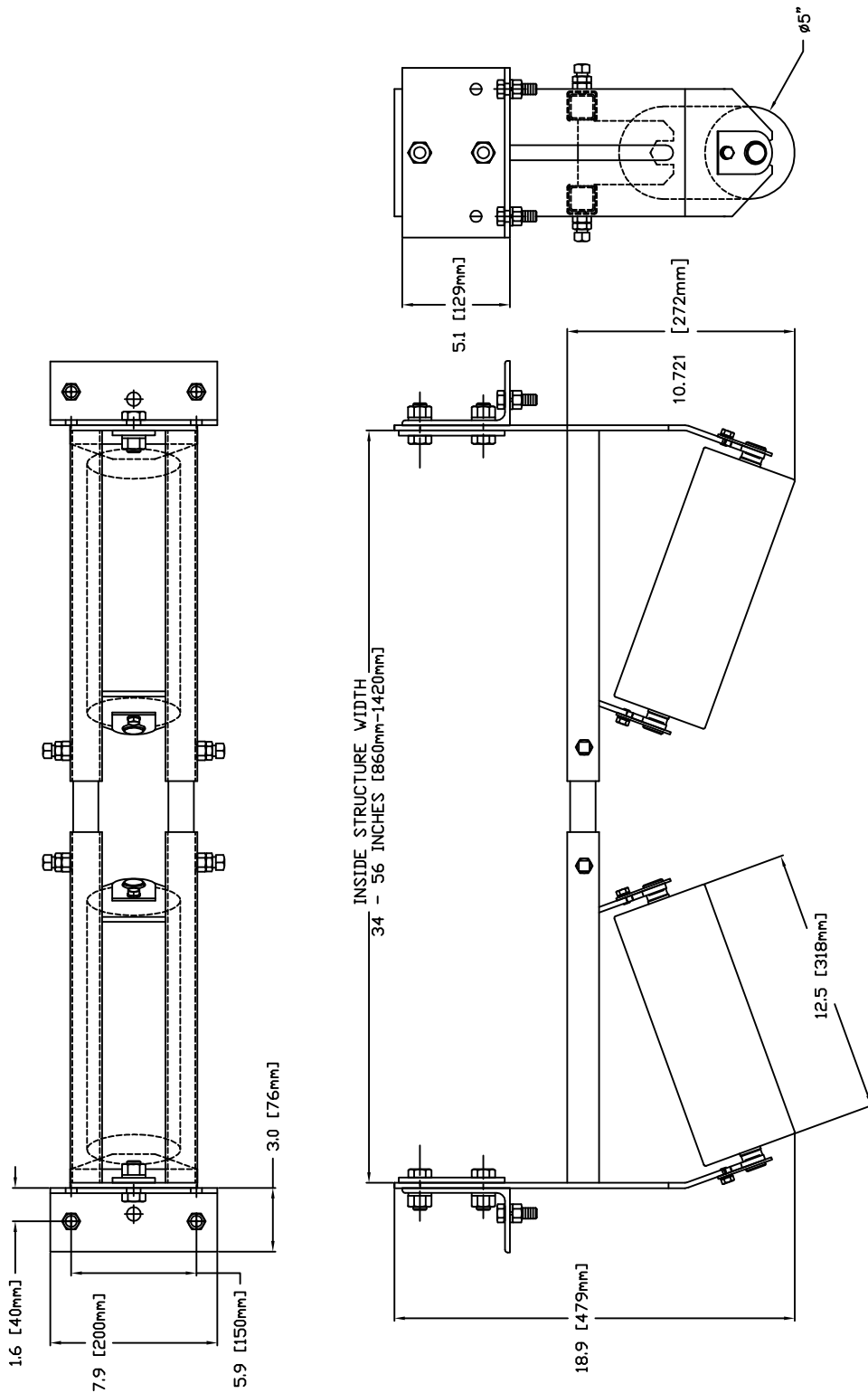

"PERSUADER" BELT POSITIONER
 SIZE: MEDIUM 73142 AND 74559
 BELT WIDTH: 30 - 48 INCHES
 INSIDE STRUCTURE WIDTH: 34 - 56 INCHES
 VERTICAL ADJUSTMENT RANGE: 8-1/8 INCHES
 VERTICAL ADJUSTMENT RANGE BY REVERSING
 MOUNTING BRACKET: 13-3/8 INCHES
 MINIMUM CLEARANCE BETWEEN BELTS - 11"

Section 8 - Specs and CAD Drawings

8.4 CAD Drawing - RBP1 Belt Positioner- Large

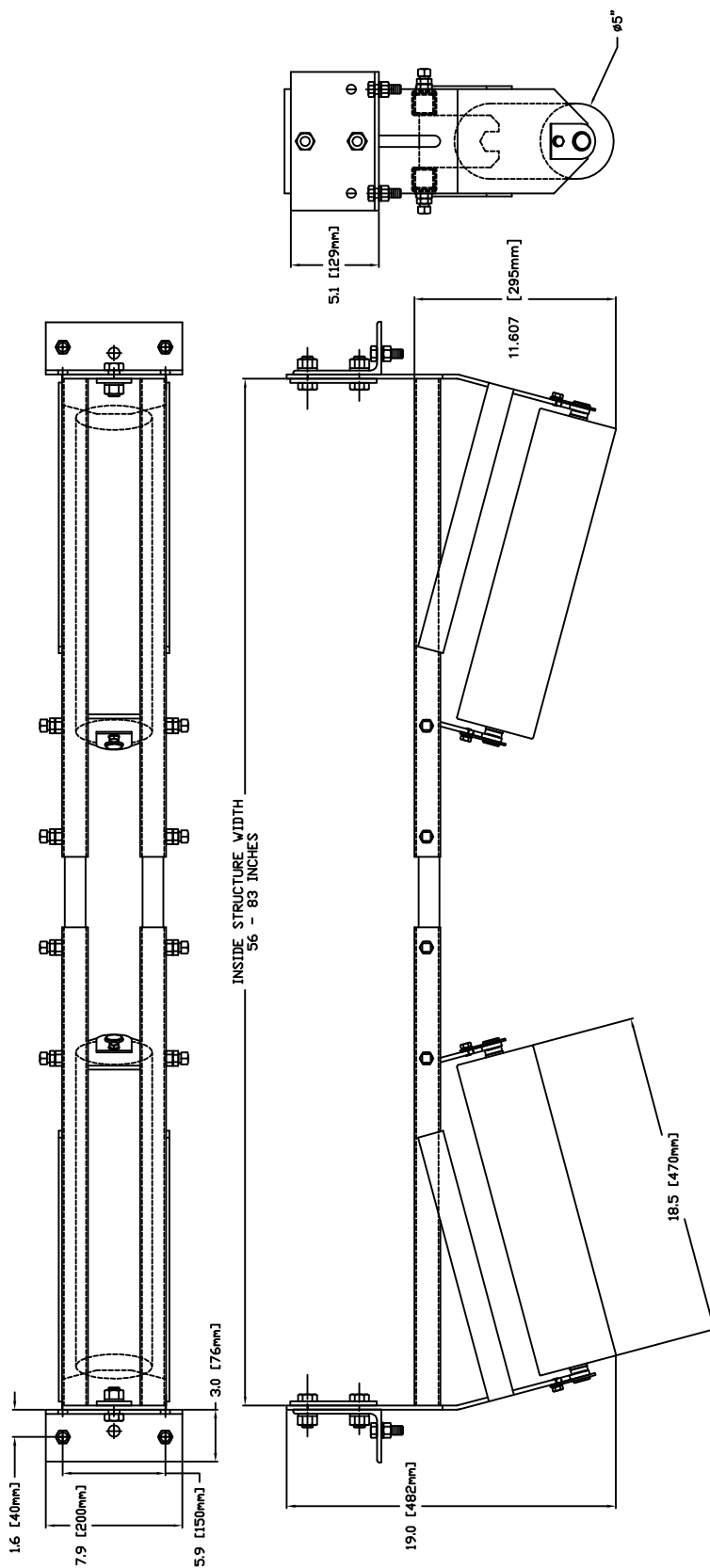

"PERSUADER" BELT POSITIONER
 SIZE: LARGE 73144 AND 74560
 BELT WIDTH: 54 - 60 INCHES
 INSIDE STRUCTURE WIDTH: 56 - 83 INCHES
 VERTICAL ADJUSTMENT RANGE: 9-1/2 INCHES
 VERTICAL ADJUSTMENT RANGE BY REVERSING
 MOUNTING BRACKET: 9-1/2 INCHES
 MINIMUM CLEARANCE BETWEEN BELTS - 12"

Section 8 - Specs and CAD Drawings

8.5 CAD Drawing - RBP1 Belt Positioner- Extra Large

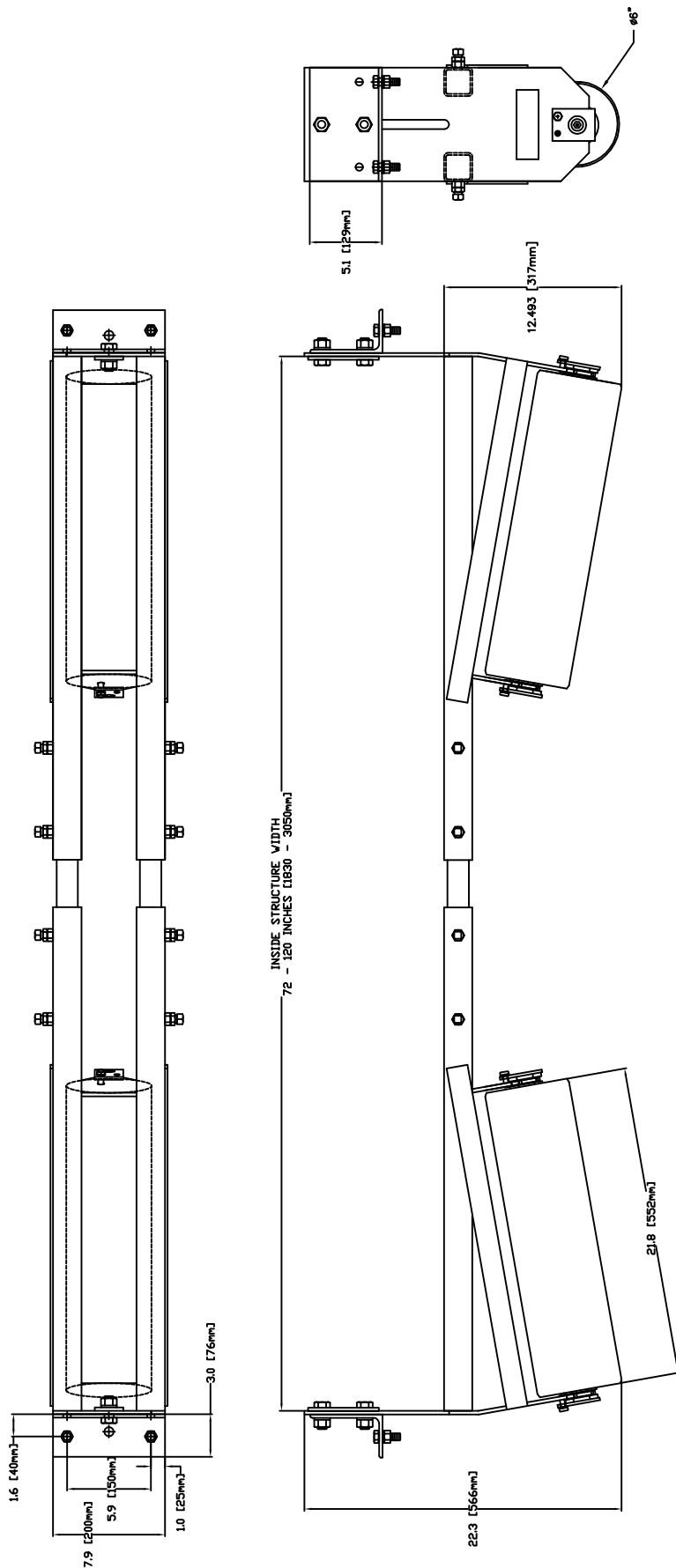

"PERSUADER" BELT POSITIONER
 SIZE: EXTRA LARGE 73146 AND 74561
 BELT WIDTH: 72 - 96 INCHES
 INSIDE STRUCTURE WIDTH: 72 - 120 INCHES
 VERTICAL ADJUSTMENT RANGE: 5-1/2 INCHES
 MOUNTING BRACKET: 10 - 1/2 INCHES
 MINIMUM CLEARANCE BETWEEN BELTS - 13"

Section 9 - Replacement Parts

9.1 Replacement Parts List

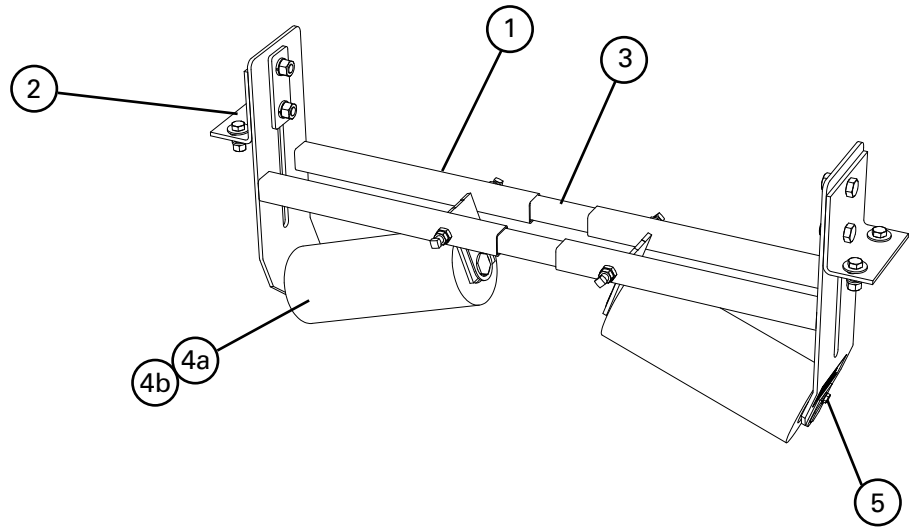

Replacement Parts

REF	DESCRIPTION	BELT WIDTH (Min-Max)		ORDERING NUMBER	ITEM CODE	WT. KG.
		mm	in.			
1	Small Frame Kit* (1 ea.)	450-600	18-24	RBPFK-S	75522	5.7
	Medium Frame Kit* (1 ea.)	750-1200	30-48	RBPFK-M	75523	6.6
	Large Frame Kit* (1ea.)	1350-1800	54-72	RBPFK-L	75524	8.9
	Extra Large Frame Kit* (1 ea.)	1800-2400	72-96	RBPFK-XL	75525	12.9
2	Mounting Bracket Kit* (1 ea.)			RBPMBK	75526	2.7
3	Small Inner Tube (1 ea.)	450-600	18-24	RBPIT-S	75527	1.4
	Medium Inner Tube (1 ea.)	750-1200	30-48	RBPIT-M	75528	2.0
	Large Inner Tube (1 ea.)	1350-1800	54-72	RBPIT-L	75529	3.0
	Extra Large Inner Tube (1 ea.)	1800-2400	72-96	RBPIT-XL	75530	4.1

* Hardware included

Lead time: 1 working day

Replacement Rollers

REF	DESCRIPTION	ORDERING NUMBER	ITEM CODE	WT. KG.
4a	Small Rubber Roller	RBPRR-S	90650	3.6
	Medium Rubber Roller	RBPRR-M	90651	5.0
	Large Rubber Roller	RBPRR-L	90652	7.0
	Extra Large Rubber Roller	RBPRR-XL	90653	12.6
4b	Small Steel Roller	RBPSR-S	74562	5.5
	Medium Steel Roller	RBPSR-M	74563	7.5
	Large Steel Roller	RBPSR-L	74564	10.5
	Extra Large Steel Roller	RBPSR-XL	74565	16.6
5	Roller Retainer Kit *	RBPRET	73163	0.2

Idler rollers on sizes S, M and L are 125mm (5") diameter and rated CEMA D.

Idler rollers on the XL size are 150mm (6") diameter and rated CEMA E.

*Roller Retainer Kit not required for XL rollers (SDX style).

Lead time: 1 working day

Section 10 - Other Flexco Conveyor Products

Flexco provides many conveyor products that help your conveyors to run more efficiently and safely. These components solve typical conveyor problems and improve productivity.

Here is a quick overview on just a few of them:

EZP1 Primary Cleaner



- Patented ConShear™ blade renews its cleaning edge as it wears
- Visual Tension Check™ for optimal blade tensioning and simple retensioning
- Quick and easy one-pin blade replacement
- Material Path Option™ for optimal cleaning and reduced maintenance

MMP Precleaner



- Extra cleaning power for tough applications
- 250mm TuffShear™ blade provides increased blade-to-belt tension
- A 3-piece telescoping pole is lighter to lift and easier to install
- Dual Quick-Mount Tensioners ensure optimal tension throughout the life of the blade

MHS Secondary Cleaner with Service Advantage Cartridge



- An easy slide-out cartridge for service
- Cartridge design to speed up blade-change maintenance
- Patented PowerFlex™ Cushions for superior cleaning performance
- Compatible with Flexco mechanical splices

Flex-Lok™ Skirt Clamps

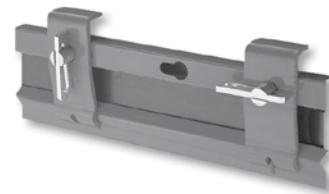

- Eliminates transfer zone spillage
- Interlocking design for easy installation and one-person maintenance
- Unique wedge pin holds rubber securely in place and is easy to adjust
- Available in various models and in stainless steel

PT Max™ Belt Trainer



- Patented “pivot & tilt” design for superior training action
- Dual sensor rollers on each side to minimize belt damage
- Pivot point guaranteed not to freeze or seize up
- Available for topside and return side belts

Belt Ploughs



- A belt cleaner for the tail pulley
- Exclusive blade design quickly spirals debris off the belt
- Economical and easy to service
- Available in vee or diagonal models

The Flexco Vision

To become the leader in maximising
belt conveyor productivity for our customers worldwide
through superior service and innovation.

Flexco Europe GmbH • Maybachstrasse 9 • 72348 Rosenfeld • Germany
Tel: +49-7428-9406-0 • Fax: +49-7428-9406-260 • E-mail: europa@flexco.com

Visit www.flexco.com for other Flexco locations and products.

©2018 Flexible Steel Lacing Company. 05/27/20. For reorder: X4345

